

# LED PLUG & PLAY TUBE

Ballast Compatible Only Tube

The LED MagicFit tube can work with specific T8 instant-start, rapid-start, programmed-start, dimming-start ballasts and existing emergency battery backup equipment.



-Aluminum & Plastic



-Nano All Plastic Lens

## DIMENSIONS

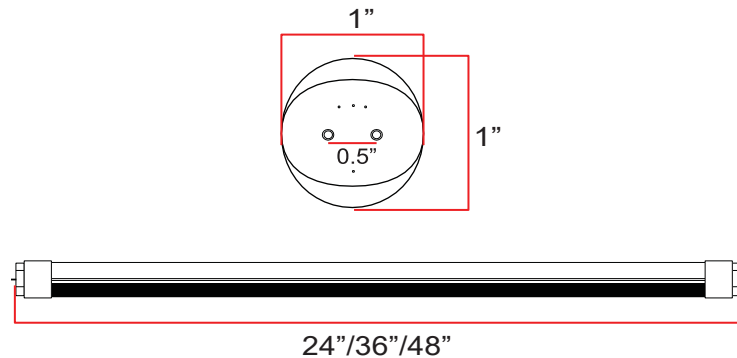

## CERTIFICATIONS



## FEATURES

- Fantastic direct replacement “plug and play” tube
- Compatible with over 90% of all North American electronic ballasts
- Glass-free for use in food areas and refrigerated food displays
- Suitable for damp or dry environments
- Minimize labor and recycling costs
- Stable lumen output for different ballast brands with different ballast factors
- UL Type A
- 5 Year Manufacturer’s Warranty

## COMMON TECHNICAL DATA

Color Temperature	3000K to 5000K
Beam Angle	240° (Aluminum/PC) 320° (Nano Plastic)
Color Consistency	4 Steps
CRI	>80
Operation Temperature	-30°C to 40°C
Efficiency with ballast	120 LPW (Aluminum) 140 LPW (Nano Plastic)
Input Voltage with ballast	100-277VAC, 347 V
Frequency	50-60Hz
Power Factor	More than 0.99
Rated Life	50,000 hrs.
LED Type	SMT 2835
Housing	Aluminum/PC Nano All Plastic Lens

## WARRANTY

This product has a warranty for a period of 5 years from the date of purchase. The warranty is invalid in the case of improper installation, tampering, or removal of the Q.C. date label. Installation in an improper working environment or installation not according to the current edition of the National Electric Code also invalidates the warranty. Should this product fail during the warranty period, it will be replaced free of charge, subject to correct installation and return of the faulty unit. James® does not accept responsibility for any installation costs associated with the replacement of this product. This warranty is in addition to the statutory rights in the country of purchase. James® reserves the right to alter specifications without prior notice.

# LED PLUG & PLAY TUBE

Plug and Play Tube

## PRODUCT SPECIFICATION

Product Number	Housing	Length (inch)	Color	Bare Lamp (Watt)	Lumens	Average System Watt (W)			Average System Lumens		
						Low Ballast Factor (0.78)	Norm Ballast Factor (0.88)	High Ballast Factor (1.10)	Low Ballast Factor (0.78)	Norm Ballast Factor (0.88)	High Ballast Factor (1.10)
BT812W4FT	Aluminum & Plastic	48"	3000K-5000K	12W	1620	13.5	14.5	16.5	1765	1885	2145
BT8P12W4FT	Nano All Plastic Lens										
BT814W4FT	Aluminum & Plastic	48"	3000K-5000K	14W	1890	15.5	16.5	18.5	2015	2145	2402
BT8P14W4FT	Nano All Plastic Lens										
BT816W4FT	Aluminum & Plastic	48"	3000K-5000K	16W	2160	17.5	18.5	19.5	2275	2405	2535
BT8P16W4FT	Nano All Plastic Lens										

## ORDERING GUIDE

B	T8/T8P	12W/14W/16W	2FT/3FT/4FT	3000K-5000K
Company Code	Housing Type	Wattage	Length	CCT

## INSTALLATION INSTRUCTIONS

Direct Replacement Procedure:

1. Turn OFF power to the fixture at the breaker panel before installation.
2. Open the diffuser from the light fixture.
3. Remove the fluorescent tubes (A) and dispose of these properly as they may contain mercury.
4. Put LED tube (B) into the lighting fixture and ensure the pins are firmly seated in lamp holders.
5. Install the LED tubes and close the diffuser.
6. Switch ON power to the fixture at the breaker panel

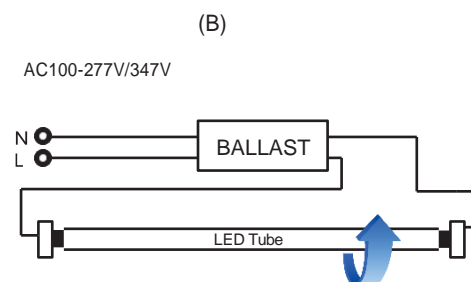
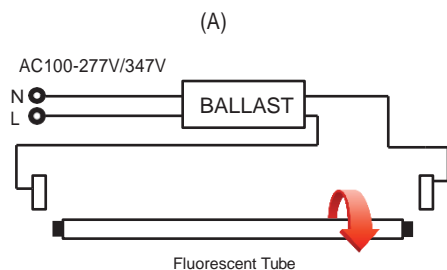

## CAUTION

- Risk of fire- do not install this lamp in a pre-heated luminaire.
- Loose or damaged end caps and/or lamp holders need to be replaced before installation.
- Risk of electric shock- make installation with gloves.
- Use only in place of fluorescent lamps specified on label.
- These lamps are intended for use with emergency exists.
- These lamps are to be used with a light dimmer.
- If the lamp or luminaire exhibits undesirable operation (i.e. buzzing, flickering, etc.), immediately turn off power and remove the lamp from luminaire and contact manufacturer.
- This lamp only operates on electronic ballasts. If lamp does not light when the luminaire is energized, remove this lamp from luminaire and contact manufacturer.
- Check the ballast installed in the field and make sure the ballast is in manufacturer's ballast list. If the ballast out of the list, a test must needed before mass installation.
- Do not make mass installation before sample testing.